

01257 276 370

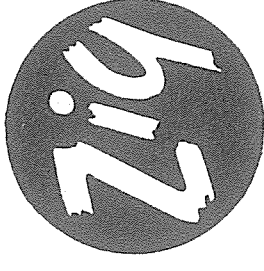

THE ZIG DCU/3 REMOTE CHARGING UNIT & POWER SUPPLY FOR CARAVANS

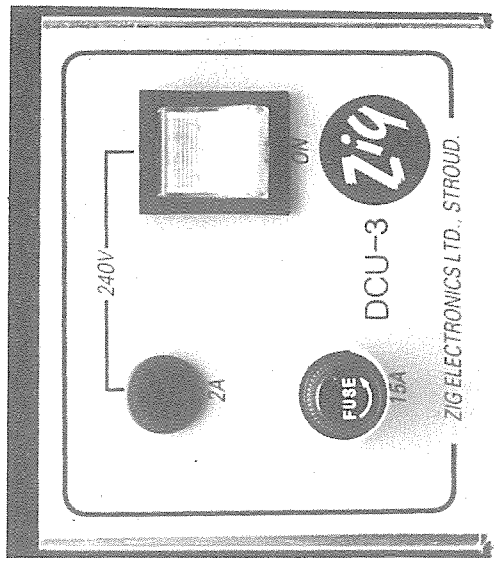

INSTRUCTIONS FOR FITTING AND USE

ZIG ELECTRONICS LTD.
CASHES GREEN
STROUD
GLOS.

ZIG ELECTRONICS LTD.,
CASHES GREEN,
STROUD,
GLOUCESTERSHIRE.
GL5 4RA.

COPYRIGHT, Peter Everard Ltd. 1988

WARNING: This document is copyright, it may not be reproduced in any form, copied, or in any way retrieved for any purpose whatsoever except with the written consent of the publishers.

INSTRUCTIONS FOR USE AND FITTING

Please read these instructions carefully before operating the electrical equipment within your caravan.

Use of your DCU/3:-

1. As a battery charger.

The DCU/3 is designed to charge and recharge your caravan or auxiliary battery, it can provide a maximum of 7.5 amps power.

2. As a mains to 12 volt converter.

The unit can provide 5 amps of smoothed usable DC to power the accessories, thus allowing a permanent hook-up situation for the duration of a holiday without worrying about the battery.

3. When mains power is not available we recommend the use of an auxiliary battery to gain full use of your Zig power supply. All manufacturers allocate a space for a new battery and the necessary cable connections. The battery must be of lead acid type, 6 cells and 12 volts. For most installations a 60 ampere/hour type will be sufficient, although there may be occasions when a 90 ampere/hour is needed. One of the latest maintenance free batteries designed for this purpose will give the best service. Car batteries are designed for starting cars and little else; investment in a specialised "Leisure Battery" will reward you with longer life and less problems.

N.B. Under no circumstances employ an old battery, always purchase a new one which should give years of service.

To install the new battery, locate in the space provided and connect the RED cable to the positive terminal and the BLACK cable to the negative terminal.

N.B. If blue and white cables are used blue is positive, white is negative. It is important to maintain a proper connection to the battery using clamp on terminals and screws. Crocodile clips must never be used in a permanent situation, they deteriorate quickly and are a fire risk. Petroleum jelly should be smeared on the terminals to reduce corrosion.

If a space has not been allocated to accommodate the battery it should be mounted upright where it cannot tip over, on a surface which is corrosion free and MUST BE VENTILATED TO THE OUTSIDE.

Connect the battery using 2mm sq. (28/03) to DCU/3 ensuring the in-line fuse is fitted in the positive line as near to the battery as possible.

Battery positive (via fuse) to terminal No.1 on DCU/3.
Battery negative (no fuse) to terminal No.5 on DCU/3.

The DCU/3 must be fixed securely to avoid any movement during towing, at the same time air must be allowed to flow freely over the unit to keep it cool, all electrical appliances generate heat and therefore run hot.

Follow these instructions for installation of the unit.

GUARANTEE

Thankyou for purchasing a Zig product.

Peter Everard Ltd., and its subsidiary Zig Electronics Ltd., Guarantee this product against failure due to faulty workmanship and/or material for a period of 12 months from the date of original purchase.

This Guarantee will be extended when the product is fitted to a caravan or motor-caravan by an original equipment manufacturer, the term will then be 12 months from the date that the caravan first became the subject of a retail sale.

It shall be at the company's discretion to determine the method of rectifying the fault.

This Guarantee is not transferable and any claims made under the Guarantee MUST be made to the supplier from whom the product was purchased. (Or to the dealer who supplied the caravan originally). It is important that proof of the date of purchase is supplied by the customer.

In the event of a claim under this Guarantee please do one of the following things:

1. Return the product or the caravan to the original supplier together with proof of the date of purchase.

2. Contact the dealer for information about repairs in situ.

Please check the section on "Fault Finding" before making any claim under the Guarantee.

IMPORTANT

This guarantee will be invalidated if any attempt has been made to open, modify or repair by unauthorised personnel.

Fuses and fuseholders are not covered for failure or damage by whatever cause.

What to do if a problem occurs outside the Guarantee period:

1. Ask your local caravan dealer if he can service the unit for you.

2. Contact a qualified electrician (or if the problem is confined to the 12 volt circuits), a qualified auto-electrician.

3. ~~If 1 and 2 above are not practical or unsuccessful, you may return the product to the manufacturers: Peter Everard Ltd., at Cashes Green, Stroud, Glos. GL5 4RA subject to the following:~~

~~(a) The product is packaged in accordance with Post Office requirements, i.e. a minimum of 2" (50mm) of packing material around the parcel. Peter Everard Ltd. will not be responsible for any damage in transit.~~

~~(b) A letter describing full details of the fault, including how and when it occurred.~~

~~(c) A cheque for £23.50 (incl. vat) made payable to Peter Everard Ltd. This is to defray charges for checking and return postage. If any repairs required exceed this figure you will be advised in writing before repairs commence. Should you decide not to proceed the above amount will be returned to you less the cost of return postage.~~

This Guarantee does not in any way affect your statutory rights.

THE FUSES

The DCU/3 is protected by 4 safety devices: two thermal trips to monitor overheating and two fuses, one protecting the mains supply and the other the 12V output.

The mains fuse is a standard 20mm x 5mm glass quick blow and can only be removed with a screwdriver or similar (this is in accordance with electrical safety regulations).

The 12V output fuse is a standard 1 1/4" (32mm) glass quick blow and can be removed without the aid of a tool. All fuses for the ZIG range are available worldwide from electrical and radio dealers.

WARNING: Under no circumstances should a fuse of different size or rating to that stated be fitted. Should a fuse blow for any reason the fault must be diagnosed before replacement.

While charging from the mains, due to the high output available from the DCU/3, the unit will run hot, this is quite normal. Should the power supply overheat it is protected by a thermal cutout which will reset automatically when normal conditions are resumed.

Your ZIG power supply is rigorously tested to the British Standard for battery chargers, B.S. 3456 part 2 section 3.25 to ensure safe use under all conditions.

WARNING

If the battery is discharged, the load drawn by the accessories in use must not exceed the rated output of the charging system.

Choose a suitable position for the DCU/3, bearing in mind the following:

1. The minimum size of the compartment for the unit must be: 125mm H; 160mm W; 205mm; this will give the minimum clearance all round which must be allowed, i.e. 25mm.
2. Air should be allowed to circulate freely over the back of the unit. Ventilation to the compartment, in the form of two 25mm holes top and bottom must be provided.
3. Access to the battery and mains supply will be required.
4. **WARNING: THIS APPLIANCE MUST BE EARTHED.**

WIRING THE 12S SOCKET.

Do NOT under any circumstances use cable smaller than that recommended. The bigger the better!

- a. Disconnect the 12S plug between the car and the van.
- b. Using cable of at least 2mm sq. (28.03), connect the negative terminals (-)ve 4 to (-ve) 3 on the 12S plug.
- c. Connect the positive terminals using the same size cable.
- d. Connect terminal 2 of the 12S plug to the positive terminal of the battery.
- e. Connect terminal 4 on the 12S plug to control panel CAR BATTERY input or to accessories (+)ve if no panel is fitted.

M.B. Accessories negative returns should be made to terminals 3, 4 or 5 on the DCU/3.

If you are wiring a motorised caravan connect No.4 to EARTH and No.1 to the main battery (+)ve VIA A SPLIT CHARGE RELAY (available from ZIG Electronics Ltd). Do not forget the 25 amp line fuse which should be as near as possible to the battery (+)ve terminal.

See "WIRING THE CAR".

THE MAINS WIRING.

Please remember that the DCU/3 does not control the mains facilities in your caravan, it only uses the mains supply to do its work.

WARNING: Mains electricity is dangerous particularly in caravans and yachts, if you do not have the necessary electrical knowledge you should entrust this part of the installation to a qualified electrician. The connection to the mains supply must be made in accordance with the I.E.E. wiring regulations for caravans.

We recommend the installation of a Residual Current Circuit Breaker also known as an Earth Leakage Circuit Breaker. This is an inexpensive way of preventing electric shock. The device fitted must be of the current operated type to the following specification:- 25 amp, 30 milliamp operating in approx. 30 milliseconds.

When all the necessary 12 volt connections have been made the mains wiring can be completed. The mains input plug and socket must be of the polarised type, (connection can only be made one way round), should you find yourself in a situation when the polarity of the supply is reversed, possibly on the continent, the operation of your Zig power supply will not be affected. You must however take immediate steps to rectify this situation because other electrical devices in your caravan could be a source of danger from electric shocks. We recommend that for touring on the continent a "Polarity tester" is used each time a connection is made on site.

The plugs and sockets are available from caravan dealers and chandlers and should be to B.S.4343. Different types may be required in Europe, but your site operator will usually be able to help.

The socket chosen may be flush or surface mounted, either must be situated near to the R.C.C.B. with the connections made between the two using 2.5mm cable not exceeding 2 metres in length. The input cable for the DCU/3 may now be connected preferably via a covered junction box as follows:-

BROWN to LIVE (marked L or red in colour)
 BLUE to NEUTRAL (marked N or black in colour)
 GREEN/YELLOW to EARTH (marked E $\frac{1}{2}$ or green in colour)

INPUT 200-240 VOLTS A.C. 50/60 HZ.

WARNING THIS APPLIANCE MUST BE EARTHED.

It is recommended that the unit is "built-in", the use of plug and socket connections is not advised.

If a 13 amp plug is used this must be connected as follows:

GREEN & YELLOW : EARTH
 BLUE : NEUTRAL
 BROWN : LIVE

As the colours of the wires in the mains lead may not correspond with the coloured markings identifying the terminals in your plug, proceed as follows.

The wire that is coloured green and yellow must be connected to the terminal in the plug which is marked with the letter "E" or the earth symbol $\frac{1}{2}$ or coloured green or green and yellow.

The wire which is coloured blue must be connected to the terminal which is marked with the letter "N" or coloured black.

The wire which is coloured brown must be connected to the terminal which is marked with the letter "L" or coloured red.

Secure all mains cable with cable clips and inspect for damage only when the wiring has been carefully checked making sure no stray strands could short to earth.

Do not connect the mains supply yet.

WIRING THE CAR.

You are strongly recommended to fit a supplementary 12S plug and socket to your car. The 12N is dedicated for use with road lighting if fog lights are to be used; also the cable used in the 12S system is of larger diameter and better suited to large current demands.

This cable must be at least 2mm sq. (28/03) and should be connected from terminal 4 on the 12S through to the vehicle battery via a 25 amp in line fuse fitted as near to the battery posts as possible. This is to protect the car and more important its passengers against fire and should NOT be omitted. The next connection should be made between terminal 3 on the 12S and an earth at the rear of the car.

The cable from Pin No.2 of the 12S socket should be connected through a relay, (available from ZIG Electronics Ltd.), and switched via the ignition switch of the vehicle, fitting will depend on the relay used. Fitting instructions are included with the ZIG RM12 and only four connections are necessary.

All the necessary car wiring is now complete and the car can be hooked to the caravan.

THE MAINS SUPPLY TO YOUR CARAVAN.

The mains to your caravan should be obtained from a domestic supply of 200 to 240 volts A.C. from a fused connection point. The mains hook up cable should be no less than 2.5mm sq. and should be regularly inspected for damage. To check the unit is functioning correctly hook the caravan to the mains supply and switch the DCU/3 on. If the 12 volt accessories work when the battery line fuse is removed all is in order.

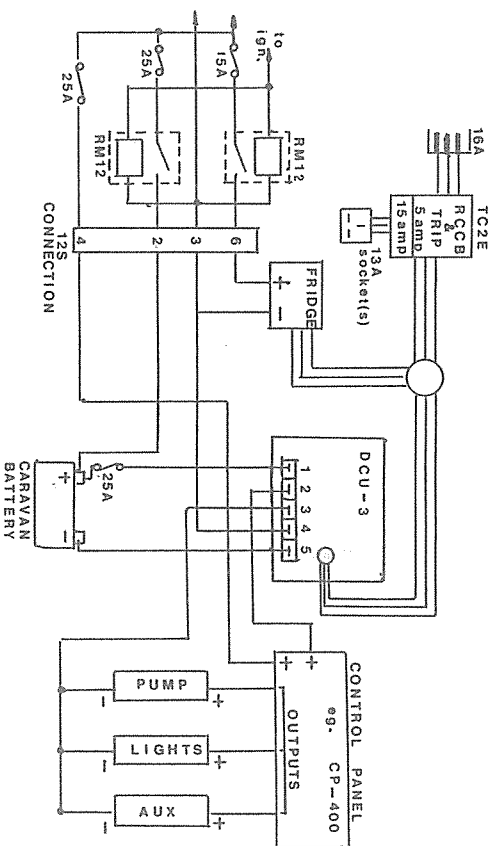

SUGGESTED WIRING DIAGRAM DCU-3