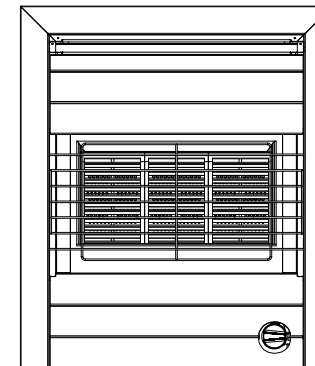

GB

IE

WIDNEY**Salerno II****Gas Fire****All Model Variants****OPERATING INSTRUCTIONS****WARNING****SAFETY GUARD**

The guard on this appliance conforms to the requirements of BS EN 13278: 2003 and satisfies the current fireguard regulations. The guard is fitted to prevent risk of fire or injury from burns and must not be removed. It does not give full protection for young children, the elderly or the infirm. It is recommended that in circumstances where children, the elderly or infirm are left unsupervised then an additional fireguard conforming to BS 8423: 2002 may be required.

GAS SAFETY

This heater must be installed by a competent gas fitter, working to the Gas Safety (Installation & Use Regulations, current edition; the Health & Safety at Work Act and the manufacturers fitting instructions. Read the User's instructions before operating.

INITIAL LIGHTING

This Appliance must:

Be installed by a Competent person.

Only be used in accordance with these instructions.

Be serviced annually by a Competent person.

Unauthorised tampering must not be permitted.

The air supply inlet and outlet openings must never be obstructed, they should be checked from time to time.

In the event of a gas leak the appliance should be turned "OFF" at its control point. Should the leak persist turn off the gas supply to the accommodation and contact a Competent person to investigate the fault/leak.

Salerno Natural gas version.

The appliance is suitable for use with G20 natural gas at a supply pressure of 20mbar for categories I_{2H} & I_{2E} and additionally G25 at a supply pressure of 25mbar (pressure couple operates) in the case of category I_{2E+} and I_{2L}.

The following lists all EC member states, which have a suitable gas supply for each category designation: -

I_{2H} :- AT, CH, CZ, DK, ES, FI, GB, GR, IE, IT, NO, PT, SE, EE, LT, LV, SI, SK. - I_{2E} :- DE, LU I_{2E+} :- BE, FR
- I_{2L} :- NL

Salerno LPG gas version.

The appliance is suitable for use with G30 Butane at a supply pressure of 29 mbar for categories I_{3B/P} & I₃₊ and G31 Propane at 37 mbar for category I₃₊ and 30mbar for I_{3B/P}

The following lists all EC member states, which have a suitable gas supply for each category designation: -

I_{3B/P} :- CZ, FI, NL, NO, SE, LT, LV, SI, SK. - I₃₊ :- BE, CH, CZ, ES, FR, GB, IE, IT, PT, EE, CY

REMOVAL OF THE FIRE FRONT: refer to Fig 1

Remove the control knob from the gas valve by pulling in the direction of the arrow (1). Pull the top of the front toward you (2) releasing off the magnets that hold it in place and then back a further approximately 50mm then lift clear of the locating tabs in the base of the fire (3).

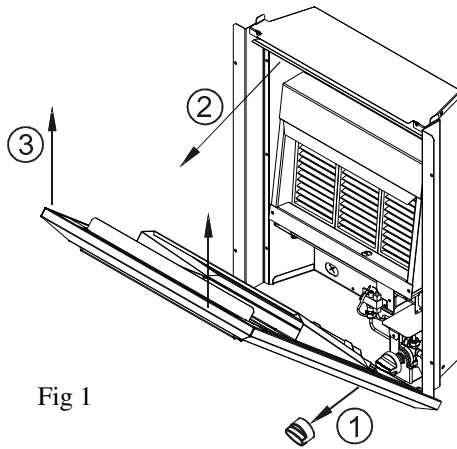

Fig 1

REPLACING THE FIRE FRONT:

Reverse above procedure taking care to locate the upturned tabs on the base panel into the slots in the lower panel return flange on the fire front.

REMOVAL AND REPLACEMENT OF THE RADIANTS AND FIREGUARD:

DO NOT ATTEMPT TO REMOVE THE RADIANTS UNLESS YOU UNDERSTAND THESE INSTRUCTIONS CLEARLY, IF IN DOUBT CONTACT A COMPETENT PERSON.

FIRE GUARD REMOVAL:

CAUTION: ENSURE THAT THE FIRE IS TURNED OFF AND THE FIRE GUARD IS COOL BEFORE REMOVING. THE FIREGUARD MUST NOT BE REMOVED PERMANENTLY.

To remove the Fireguard carefully pull its centre toward you, this will release the locating lugs from the holes in the chrome trim.

Care should be taken not to distort the Fire guard or damage the chrome trim.

To replace, insert the lugs on one side of the fire guard into the holes in the chrome trim, bend the guard slightly so the lugs on the opposite side line up with the holes in the chrome trim, insert the lugs and gently push the centre of the guard inward to ensure that all lugs are correctly located.

RADIANT REMOVAL:

Remove the Radiant retention panel by removing the two screws (one at each side).

Lift the centre Radiant up approximately 10mm and pull the base forward to clear the radiant carrier, and then remove the Radiant. Slide either of the remaining two to the centre and remove as before, finally repeat the procedure for the one remaining.

RADIANT REPLACEMENT:

Place the first Radiant in the centre of the combustion chamber and insert the top edge under the combustion chamber canopy, then lower the Radiant into the radiant carrier and slide to one side.

Repeat the procedure for the remaining two with the centre radiant being the last one to be fitted.

Replace the radiant retention panel.

WIDNEY LEISURE LTD

APPLIANCE DETAILS

The information below will be needed by Widney Leisure if you require any servicing or replacement parts.

Appliance Serial no: This number is found on the data label adhered to the appliance chassis at the rear (only visible when front case removed). Serial No	
Home Name or Number	
Holiday Home Manufactures Name	
Holiday Home Serial Number	
Date when Home Purchased	
Date when Appliance purchased if different from above.	
Address where Fire is located	
Your Address:	
Describe Type of Fault (Please describe)	
Supply Pressures: I ₃₊ (28 – 37) - I _{3B/P} (28 – 30) - I _{2H} / I _{2E} (20) - I _{2L} / I _{2E+} (25) Propane @ 37mbar +/- 2 mbar and 30mbar +/- 2 mbar , Butane @ 28mbar +/- 2mbar, Natural Gas @ 20mbar +/- 1mbar and 25mbar +/- 1mbar Pressure at control pressure test point: Butane 28 +/- 2mbar Propane 36.5 +/- 2 mbar, and 29.5 +/- 2mbar Natural Gas 19.4 +/- 1mbar, and 24 +/- 1mbar <i>(This pressure should be measured at the appliance when all other appliances are turned on) Please contact your local Competent Gas Engineer to provide this detail</i>	
Pressure	Gas Type.....
Installation engineers contact details:	
Serial number:	WIDNEY LEISURE LTD. SAXON BUSINESS PARK, HANBURY ROAD, STOKE PRIOR, BROMSGROVE, WORCESTESHIRE, B60 4AD, ENGLAND. TELEPHONE: 01527 577800 Email: sales@widney-leisure.co.uk Web: www.widney-leisure.co.uk

WIDNEY

GUARANTEE

This product is guaranteed against faulty parts or workmanship for 12 months from the date of purchase, providing the product is installed in accordance with our instructions. This guarantee does not extend to light bulbs which are considered consumable items.

To validate the guarantee the following information must be supplied. Widney Leisure is not responsible for any cost incurred in the pursuit of warranty work unless these are authorised in advance.

When making a claim under warranty you must provide the a details requested opposite otherwise your warranty might be invalid.

Widney Leisure Ltd reserves the right to refuse warranty for any product returned that does not have valid proof of date of Purchase.

This guarantee does not affect your statutory rights.

FIRE OPERATION:

READ THESE INSTRUCTIONS BEFORE LIGHTING YOUR FIRE.

(Your installer should give you instruction on how to operate this appliance).

When the fire is first lit, it should be run on high setting for about 1 hour. Ensure the room is well ventilated and all doors and windows are open, this is to allow for any residual lubricants remaining from the manufacturing process to burn off.

TO LIGHT THE FIRE:

The fire has an integral ignition system which will light the pilot and main burner flame on initial lighting. Ensure that the gas valve is in the off position as indicated in the diagram.

1. Depress the gas control knob and turn anticlockwise rapidly (Two Clicks will be heard), the fire should now be lit. The main burner and pilot can be viewed via the small round hole in the chrome trim just in front of the radiants. **WARNING: do not get too close to the fire.**
2. After rotating the control knob hold in the depressed position for approximately 10 seconds this will allow the thermocouple safety device to operate.
3. Once lit the fire control can be turned anti-clockwise to full heat or any position between low and high for the desired output.

If the fire fails to ignite on the first attempt repeat the procedure in rapid succession 3 times. If the fire has not lit after 3 attempts leave for 5 minutes and repeat steps 1 to 3.

In some cases the fire may need several attempts to ignite if the gas supply has recently been replaced.

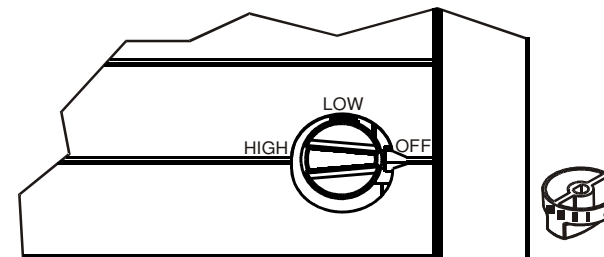

CONTROL POSITIONS

WHAT TO DO IF YOUR APPLIANCE IS FAULTY OR YOU REQUIRE SPARES: (DO NOT TAMPER WITH THE FIRE)

1. Check the simple fault chart to identify the problem, if in doubt consult a Competent Gas Engineer for assistance.
2. Complete the attached Guarantee Card.
3. Contact the reseller of the product and request assistance.

Contact your retailer for spare parts as listed.

Useful Numbers and Contact Information:
Widney Leisure Ltd +44(0)1527 577800
Email sales@widney-leisure.co.uk

If you are unable to contact the reseller please contact Widney Leisure directly at the address listed on the guarantee card.





All Widney products are guaranteed against normal operation for a period of 12 months from the date of purchase providing they have been installed in accordance with the instructions. Widney reserve the right to refuse or charge for any work if the above terms are not complied with.

WIDNEY LEISURE GAS FIRE TROUBLE SHOOTING TABLE

	Fault	Action	I still have a problem	Action	I still have a problem
1	Fire will Not Ignite	Check gas pressure at fire	If pressure is correct see item2		See trouble shooting headings for further assistance: If Fault not listed contact: Widney Leisure Customer Service
2	The pilot does not spark	Check spark Gap	Spark Gap is correct but has no spark	Replace gas valve and pilot assembly.	As Above
3	Fire Ignition Sparks but does not light	Check pilot jet for blockage	Pilot is clear but no gas coming through	Check Main Gas Valve for blockage	As Above
4	Pilot light ignites but main burner does not ignite	Check main injector for blockage	The main injector is clear but the fire does not ignite	Check Main Gas Valve for Blockage	As Above
5	Main burner ignites but flame is very low	Check main injector for blockage	The main injector is clear	Check for blockage in main gas valve and pipe work	As Above
6	The main gas valve is blocked	Replace gas valve	See trouble shooting headings for further assistance: If Fault not listed contact: Widney Leisure Customer Sservice		
7	The gas feed pipe is blocked	Replace gas feed pipe	As Above		
8	Ceramic Radiant turning black (Sooting)	Ensure that no direct draft is entering the fire	There are no drafts around the fire	Check to ensure radiants are correctly fitted	As Above
9	The main burner is blocked	Replace burner	See trouble shooting headings for further assistance: If Fault not listed contact: Widney Leisure Customer Service		
10	Fire burns with yellow flame	Ensure that no direct draft is entering the fire	There are no drafts around the fire	Check main injector for blockage	Contact Widney Leisure Customer Service
11	Fire Flame fluctuates	Ensure that no direct draft is entering the fire	There is a draft from the rear of the fire	Contact: Widney Leisure Customer Service	
12	Fire appears to be overheating	Check gas pressure at fire	The gas pressure is correct	Contact: Widney Leisure Customer Service	
13	Fire does not get hot enough	Check main injector for blockage	The injector is clear	Check gas pressure at fire	As Above

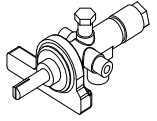
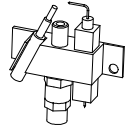
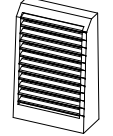
SHORT PARTS LIST

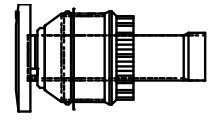
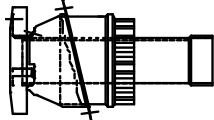
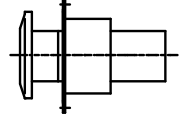
The illustrated short parts list includes part numbers.
When ordering quote gas fire name with part number & description.

Gas Train	PART NUMBER	DESCRIPTION
	W00018	Control Valve with rotary ignition (LPG)
	W00166	Control Valve with rotary ignition (NG)
	W00020	Oxygen depletion device / pilot assembly (LPG)
	W00170	Oxygen depletion device / pilot assembly (NG)
	RA002	Radiant (pack of 3)
	W00028	Burner Injector (LPG)
	W00167	Burner Injector (NG)
	W99901	Straight Terminal with Vent Plain Finish. <i>For other finishes please contact customer services</i>
	W99801	Angled Terminal with Vent. Plain Finish. <i>For other finishes please contact customer services</i>
	W99600	Straight Terminal Non Vented. Plain Finish. <i>For other finishes please contact customer services</i>
	W00213	Terminal with Vent Pantile Roof <i>For other finishes please contact customer services</i>