

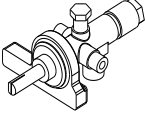

## SHORT PARTS LIST

The illustrated short parts list includes part numbers.  
When ordering quote gas fire name with part number & description.

| Gas Train                                                                           | PART NUMBER | DESCRIPTION                                                                                              |
|-------------------------------------------------------------------------------------|-------------|----------------------------------------------------------------------------------------------------------|
|    | W00018      | Control Valve with rotary ignition (LPG)                                                                 |
|                                                                                     | W00166      | Control Valve with rotary ignition (NG)                                                                  |
|    | W00020      | Oxygen depletion device / pilot assembly (LPG)                                                           |
|                                                                                     | W00170      | Oxygen depletion device / pilot assembly (NG)                                                            |
|    | RA002       | Radiant (pack of 3)                                                                                      |
|    | W00028      | Burner Injector (LPG)                                                                                    |
|                                                                                     | W00167      | Burner Injector (NG)                                                                                     |
|    | W99901      | Straight Terminal with Vent Plain Finish.<br><i>For other finishes please contact customer services</i>  |
|   | W99801      | Angled Terminal with Vent Plain Finish.<br><i>For other finishes please contact customer services</i>    |
|  | W99600      | Straight Terminal Non Vented Plain Finish.<br><i>For other finishes please contact customer services</i> |
|   | W00213      | Terminal with Vent Pantile Roof<br><i>For other finishes please contact customer services</i>            |

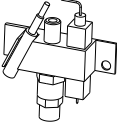
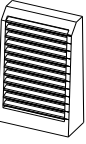

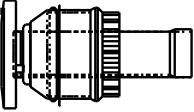
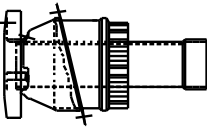
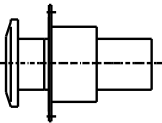
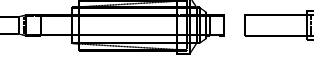
# WIDNEY

## Salerno II

Gas Fire

All Model Variants

### INSTALLATION & MAINTENANCE INSTRUCTIONS

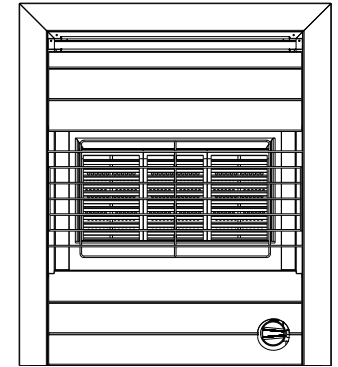

**READ THESE INSTRUCTIONS BEFORE INSTALLING OR SERVICING THE FIRE**  
**IMPORTANT:** Before installation ensure that the local distribution conditions (identified by the type of gas and pressure) and the adjustment of the appliance are compatible.

#### Salerno Natural Gas Version.

The appliance is suitable for use with G20 natural gas at a supply pressure of 20mbar for categories I<sub>2H</sub> & I<sub>2E</sub> and additionally G25 at a supply pressure of 25mbar (pressure couple operates) in the case of category I<sub>2E+</sub> & I<sub>2L</sub>. The following lists all EC member states, which have a suitable gas supply for each category designation:

I<sub>2H</sub>:- AT, CH, CZ, DK, ES, FI, GB, GR, IE, IT, NO, PT, SE, EE, LT, LV, SI, SK  
I<sub>2E</sub>:- DE, LU - I<sub>2E+</sub>:- BE, FR—I<sub>2L</sub>:- NL

#### Salerno LPG Gas Version.

The appliance is suitable for use with G30 Butane at a supply pressure of 28-30 mbar and G31 Propane at a supply pressure of 37 mbar for category I<sub>3+</sub>. It is also suitable for G30 Butane and G31 Propane at a supply pressure of 30mbar for I<sub>3B/P</sub>. The following lists all EC member states, which have a suitable gas supply for each category designation:

I<sub>3B/P</sub>:- CZ, FI, NL, NO, SE, LT, LV, SI, SK  
I<sub>3+</sub>:- BE, CH, CZ, ES, FR, GB, IE, IT, PT, EE, CY

It is a legal requirement that all gas appliances are installed by a competent person in accordance with the Gas Safety Installation and Use Regulations 1994. Failure to install the appliance as stated can lead to prosecution, it is in your interests that the law is complied with.

Installation and Ventilation requirements shall be in accordance with these Installation Instructions, BS EN 1949:2002, BS EN 721:1999, BS5871 and BS EN 1647:1999.

For the Republic of Ireland the installation must be carried out by a competent person and also conform to the relevant parts of : The current edition of IS 813—Domestic Gas Installations  
All relevant national and local rules in force

#### WIDNEY LEISURE LTD.

SAXON BUSINESS PARK, HANBURY ROAD,  
STOKE PRIOR, BROMSGROVE,  
WORCESTERSHIRE B60 4AD ENGLAND  
TELEPHONE: +44(0)1527 577800

Email: sales@widney-leisure.co.uk web: www.widney-leisure.co.uk

## PREPARATION OF THE FIRE:

**Note:** Before commencing installation it is recommended that you fill in the appliance details on the rear of the user's instruction.

### REMOVAL OF THE FIRE FRONT: refer to Fig 1

Remove the control knob from the gas valve by pulling in the direction of the arrow (1). Pull the top of the front toward you (2) releasing off the magnets that hold it in place and then back a further approximately 50mm then lift clear of the locating tabs in the base of the fire (3).

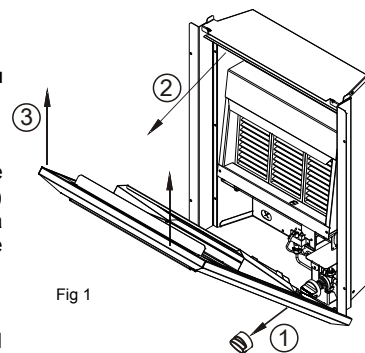

Fig 1

### REPLACING THE FIRE FRONT:

Reverse the above procedure taking care to locate the upturned tabs on the base panel into the slots in the lower panel return flange on the fire front.

### LOCATION:

When locating the fire ensure that the minimum thermal lift of 1690mm as indicated in figure 4 can be achieved.

### PREPARING THE APERTURE:

Cut an aperture in the furniture to the following dimensions: 560mm High x 440mm Wide, this ensures a minimum 5mm air gap between the fire back and the furniture is maintained.

It is recommended that the base of the fire is supported and no room air is allowed to enter the cavity from under the fire base (See fig 2).

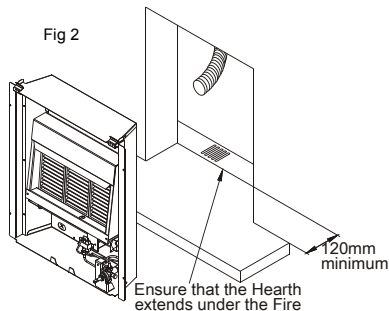

Fig 2

### FITTING THE FIRE:

The fire must only be fitted with recommended flue liner and terminals - please consult the supplier for further information. The flue liner needs to be prepared prior to fitting. Refer to these instructions and Fig 4 for this stage.

Depending on the construction of the flue cavity, the flue liner can be installed before or after the fire back is fastened into position. In any installation, the flue liner must be pushed fully over the fire back flue spigot and secured to the fire and Terminal spigot using steel self-tapping fasteners which will retain the liner into full position to the terminal/fire spigots. Under no circumstances must the liner be left installed without a sound connection and the position unfastened.

The fire should be installed as fig 3 with self tapping screws through the 2 fixing brackets on the sides of the main fire chassis to the fire surround.

Any materials, coatings or finishes used in the construction of the fire surround and hearth must be specified to tolerate the full radiated and convected and conducted heat from the fire.

### POSITION OF COMBUSTIBLE MATERIALS:

It is recommended that no fixed combustible materials are located within 500mm of the centre line of the fire – measured from the centre radiant. Any combustible materials used for the construction of the fireplace that are not subject to direct line of sight to the ceramic radiants must be able to tolerate the radiated, conducted and convected heat of the appliance when operated at full rate. The materials used must comply with the relevant British or EN standard / Code of Practice for this installation. Note: It is the responsibility of the installer to ensure that any material used adjacent to or adjoining the appliance is fit for purpose. Any loose furnishings should not be placed within the dimensions as indicated in (Figure 3)

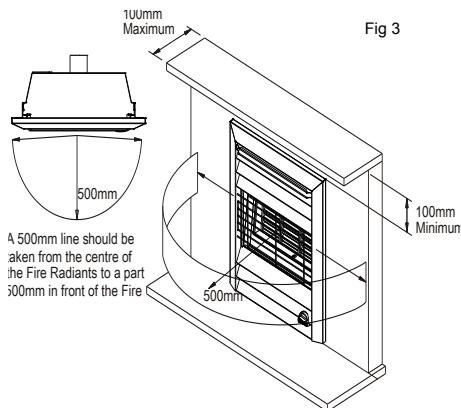

Fig 3

## WIDNEY LEISURE GAS FIRE TROUBLE SHOOTING TABLE

|    | Fault                                               | Action                                           | I still have a problem                                                                                                 | Action                                             | I still have a problem                                                                                                 |
|----|-----------------------------------------------------|--------------------------------------------------|------------------------------------------------------------------------------------------------------------------------|----------------------------------------------------|------------------------------------------------------------------------------------------------------------------------|
| 1  | Fire will Not Ignite                                | Check gas pressure at fire                       | If pressure is correct see item2                                                                                       |                                                    | See trouble shooting headings for further assistance: If Fault not listed contact: Widney Leisure Ltd Customer Service |
| 2  | The pilot does not spark                            | Check spark Gap                                  | Spark Gap is correct but has no spark                                                                                  | Replace gas valve and pilot assembly.              | As Above                                                                                                               |
| 3  | Fire Ignition Sparks but does not light             | Check pilot jet for blockage                     | Pilot is clear but no gas coming through                                                                               | Check Main Gas Valve for blockage                  | As Above                                                                                                               |
| 4  | Pilot light ignites but main burner does not ignite | Check main injector for blockage                 | The main injector is clear but the fire does not ignite                                                                | Check Main Gas Valve for Blockage                  | As Above                                                                                                               |
| 5  | Main burner ignites but flame is very low           | Check main injector for blockage                 | The main injector is clear                                                                                             | Check for blockage in main gas valve and pipe work | As Above                                                                                                               |
| 6  | The main gas valve is blocked                       | Replace gas valve                                | See trouble shooting headings for further assistance: If Fault not listed contact: Widney Leisure Ltd Customer Service |                                                    |                                                                                                                        |
| 7  | The gas feed pipe is blocked                        | Replace gas feed pipe                            | As Above                                                                                                               |                                                    |                                                                                                                        |
| 8  | Ceramic Radiant turning black (Sooting)             | Ensure that no direct draft is entering the fire | There are no drafts around the fire                                                                                    | Check to ensure radiants are correctly fitted      | As Above                                                                                                               |
| 9  | The main burner is blocked                          | Replace burner                                   | See trouble shooting headings for further assistance: If Fault not listed contact: Widney Leisure Ltd Customer Service |                                                    |                                                                                                                        |
| 10 | Fire burns with yellow flame                        | Ensure that no direct draft is entering the fire | There are no drafts around the fire                                                                                    | Check main injector for blockage                   | Contact Widney Leisure Ltd Customer Service                                                                            |
| 11 | Fire Flame fluctuates                               | Ensure that no direct draft is entering the fire | There is a draft from the rear of the fire                                                                             | Contact: Widney Leisure Ltd Customer Service       |                                                                                                                        |
| 12 | Fire appears to be overheating                      | Check gas pressure at fire                       | The gas pressure is correct                                                                                            | Contact: Widney Leisure Ltd Customer Service       |                                                                                                                        |
| 13 | Fire does not get hot enough                        | Check main injector for blockage                 | The injector is clear                                                                                                  | Check gas pressure at fire                         | As Above                                                                                                               |

As with any gas fire the fire must be installed by a Competent person in accordance with the gas safety (Installation and Use) Regulations 1998. It is recommended that a competent person in line with the service instructions in the Installation and Maintenance Manual services the appliance annually.

#### MAINTENANCE:

Before carrying out maintenance turn off the gas supply. Removal of the fire front is necessary before any maintenance can take place.

#### SPILLAGE:

Test for spillage in accordance with the procedure Page 5.

#### CLEANING:

Clean inside the appliance with a soft brush, and then vacuum to remove all dust and lint particles each year or more regularly if deterioration in performance is noticed.

#### CONTROLS:

If it is necessary to remove or replace parts of the control system, remove the gas control valve from the fire after first disconnecting the gas supply pipe, and the feed pipes to both the burner and pilot assembly. Disconnect the thermocouple and electrode lead by unscrewing the main lock nut, and remove the valve from the bracket.

#### CLEANING THE INJECTOR:

Remove the gas feed pipe from the valve to the injector. Remove the injector from the burner, check to see if it is blocked. To clean the injector, blow out with compressed air. Do not clean with any object that may cause damage to the injector.

#### IGNITION SYSTEM:

There is no maintenance needed on the piezo spark generator, which is an integral part of the control valve.

#### ELECTRODE AND THERMOCOUPLE: - (see fig 6)

There is no adjustment of the electrode. The whole oxy pilot assembly is pre-factory set and is available as a spare.

#### PILOT/OXYGEN ANALYZER: - (see fig 6)

The pilot/oxygen analyzer device is preset at the factory, and cannot be adjusted. To remove the device unscrew the clamp screw, unscrew the tube nut and withdraw the unit. To replace the device reverse the operations above.

**Note:** In the event of repeated intervention (lockout) by the above device the flue operation should be checked first (see spillage test).

**Under no circumstances should the pilot/oxygen analyzer be put out of action or overridden.** Only Widney parts should be used in the event of assembly replacement.

#### FLUE AND TERMINAL CHECKS:

At least once a year checks are recommended on both the flue and the terminal.

Check that they are not blocked in any way and that there are no signs of corrosion, deterioration or damage. If there are then replacement is necessary.

#### DO NOT OVER TIGHTEN ANY TUBE NUT

When remaking any gas joint with an olive it is normally sufficient to hand tighten the nut until it locks onto the olive. Then a further half turn with a spanner is normally sufficient to ensure the joint is gas tight.

**Always leak test any re-made gas joints in the fire before handing over to user.**

All the above should be carried out by a Competent Person.

**If in doubt contact Widney Leisure Customer Service. (01527 577800)**

#### FLUE CAVITY & ROOM VENTILATION:

##### FLUE CAVITY:

It is recommended that the flue cavity is vented to avoid build up of heat and to ensure that internal surface temperatures within the cavity do not exceed a 50°C rise.

Note: It is important to position the flue cavity ventilation as far as possible from the rear of the fire.

##### VENTILATION GUIDELINES:

**Warning excessive ventilation should be avoided as this may result in flame disturbance.**

- A) The flue cavity should be vented with a minimum combined upper and lower level ventilation of 2,000mm<sup>2</sup> and a maximum of 5,000mm<sup>2</sup> Free air. Except where an approved vented terminal is fitted ensure that the cavity is ventilated to avoid excessive build up of heat. Ensure that the fire is shielded from direct flue cavity ventilation to reduce the effect of wind entering the cavity.
- B) For appliances fitted with approved vented terminals W00213, W99901, W99801 Top Side vents should not be fitted.

##### ROOM VENTILATION:

Positioning of room ventilation is specific to each home; however care should be taken when sighting ventilation to avoid drafts or air movement across the face of the appliance

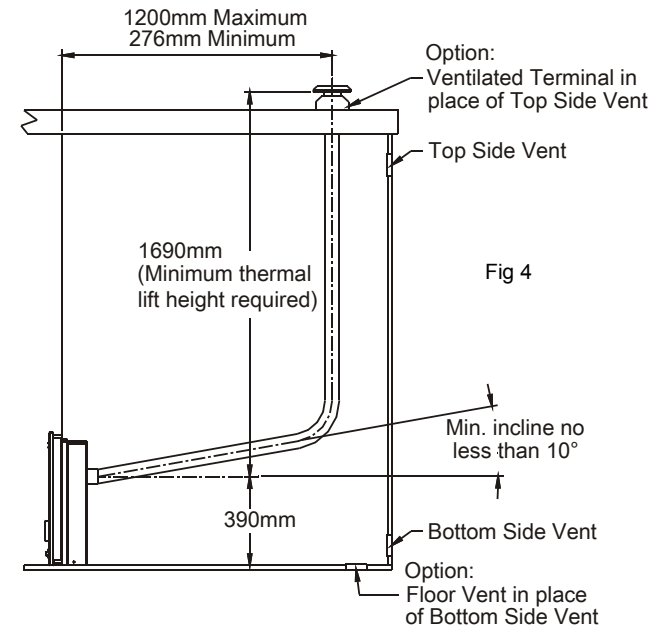

##### FLUE LINER INSTALLATION:

IT IS IMPORTANT TO ENSURE THAT THE FLUE IS CORRECTLY SEALED AND INSTALLED TO ENSURE THAT THE FLUE GASES WILL MAINTAIN A TEMPERATURE ABOVE THE DEW POINT OF 132°C. A MINIMUM THERMAL LIFT OF 1690mm IS REQUIRED – THIS IS MEASURED FROM THE FLUE SPIGOT OUTLET TO THE TERMINAL OUTLET - (See Fig 4)

The flue liner should be installed and fixed to the fire flue spigot by means of a self tapping screw and or a spring clip. The flue liner must rise continually from the spigot of the appliance with no less than a 10 deg incline from the horizontal. The length of the flue liner must be sufficient to ensure that the minimum thermal lift of 1690 mm is achieved.

**TERMINAL INSTALLATION:** Several types of terminal are available to suit both flat and pitched roof homes. Please contact your supplier for further information. Only flue terminals of an approved type must be fitted to the appliance. For information on approved terminal please see terminal guide at the end of this manual.

Install the terminal by cutting a clearance hole in the roof of the holiday home. Insert the terminal through the hole and seal with a suitable material, and secure through fixing holes provided with self-tapping screws. Connect the flue liner to the fire spigot at the rear of the fire and secure it with a screw and or spring clip. Shape the flue liner to the required position and connect to the terminal ensuring the flue liner rises continually from the rear of the fire to its termination. The flue liner must be supported to ensure that a minimum gap of 50mm is maintained between the flue liner and any combustible material.

##### IMPORTANT NOTE:

**Please ensure that the terminal is clear from any obstruction prior to operating the appliance.**

## CONNECTION OF GAS SUPPLY:

Connect the supply of gas to the gas control by means of a 5/16" (8mm) o/d pipe. The supply pipe connects directly into adaptor fitted to gas control inlet. The adaptor is clearly visible on the left hand side of the heat shield that is located over the control tap. The nuts should be tightened sufficiently to seal the joint, but not over tightened as this will result in damage to the olives and could cause failure of the nut.

## RADIANT INSTALLATION:

Remove the Radiant retention panel.

Place the first radiant in the centre of the combustion chamber and insert the top edge under the combustion chamber canopy, then lower the radiant into the radiant carrier and slide to one side. Repeat the procedure for the remaining two with the centre radiant being the last one to be fitted. Replace the Radiant retention panel.

### SPECIFICATION:

|                                      |                                                                                 |
|--------------------------------------|---------------------------------------------------------------------------------|
| Overall height:                      | 635mm                                                                           |
| Overall width:                       | 585mm                                                                           |
| Overall depth:                       | 250mm (including spigot length)                                                 |
| Wall opening:                        | 560mm High x 440mm Wide                                                         |
| Weight:                              | 10Kg                                                                            |
| Heat input:                          | Max: 3.8 kW Gross<br>Min: 1.9 kW Gross                                          |
| Gas Connection:                      | Suitable for connection to 5/16" or 8mm copper pipe with olive and nut.         |
| Burner:                              | Worgas Type POO -2041                                                           |
| Injector:                            | Widney W00028 (1.02mm) LPG<br>Widney W00167 (1.48mm) NG                         |
| Pressure test point:                 | On Control Valve                                                                |
| Pilot/Oxygen depletion device:       | Copreci Pt. No. "21100/181" W00020 LPG<br>Copreci Pt. No. "21100/182" W00170 NG |
| Control Valve with Rotary Piezo:     | Copreci W00018 LPG<br>Copreci W00166 NG                                         |
| Appliance efficiency classification: | 1                                                                               |

### Gas Consumption

#### Tap Position

| Gas type      | High                      | Low                       |
|---------------|---------------------------|---------------------------|
| G20           | 0.362 m3/hr               | 0.181 m3/hr               |
| G25           | 0.421 m3/hr               | 0.211 m3/hr               |
| G30           | 0.108 m3/hr (0.28 kg/hr)  | 0.054 m3/hr (0.14 kg/hr)  |
| G31 (37 mbar) | 0.143 m3/hr (0.27 kg/hr)  | 0.072 m3/hr (0.135 kg/hr) |
| G31 (30 mbar) | 0.129 m3/hr (0.243 kg/hr) | 0.065 m3/hr (0.122 kg/hr) |

|             | Gas category      | Gas           | Pressure at control pressure test point:   |
|-------------|-------------------|---------------|--------------------------------------------|
| Natural gas | I <sub>2H</sub>   | G20           | 19.4 +/- 1 mbar                            |
|             | I <sub>2E</sub>   | G20           | 19.4 +/- 1 mbar                            |
|             | I <sub>2E+</sub>  | G20           | 19.4 +/- 1 mbar                            |
|             | I <sub>2L</sub>   | or G25        | 24.0 +/- 1 mbar                            |
| LPG         | I <sub>3B/P</sub> | G30<br>or G31 | 28 mbar +/- 2 mbar<br>29.5 mbar +/- 2 mbar |
|             | I <sub>3+</sub>   | G30           | 28 mbar +/- 2 mbar                         |
|             |                   | G31           | 36.5 mbar +/- 2 mbar                       |

## INSTALLATION CHECKS - SERVICE AND MAINTENANCE:

### TESTING THE INSTALLATION:

#### AFTER INSTALLATION THE FOLLOWING CHECKS SHOULD BE COMPLETED BY A COMPETENT PERSON:

- The appliance should be checked for gas soundness. This should be carried out using a suitable leak test fluid (**NOT A NAKED FLAME**)
- The setting pressure should be checked and adjusted to the recommendations detailed on the specification sheet with all appliances on.
- The operation of the controls, e.g. ignition device, flame failure etc., should be checked for satisfactory performance.
- Ignition System. A piezo crystal in the gas control valve operates the ignition system. Depress the gas control knob and turn anticlockwise rapidly (Two Clicks will be heard). If the fire does not ignite after any air in the gas supply pipe has been purged check electrode setting – Dimension between the tip of the thermocouple and the tip of the electrode should be 4.0mm <sup>-0/+0.5</sup> (see fig 5).
- The operation of the flame failure device should be checked for satisfactory performance.
- Test for spillage (see fig 6).

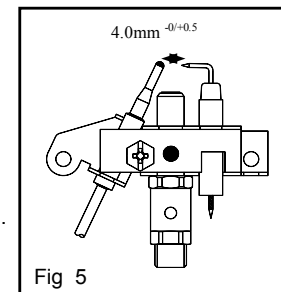

Fig 5

#### A SPILLAGE TEST MUST BE PERFORMED BEFORE THE INSTALLATION IS APPROVED.

The Spillage test must be carried out in accordance with BS 5440 -1 2008 - 6.3.2.3 or later, and the following instructions.

- Remove the Dress-guard.
- Light the fire at full rate.
- After 10 minutes carry out a spillage test as follows:

Turn off and insert a lighted smoke pellet or match into position indicated in diagram below.

Fig 6

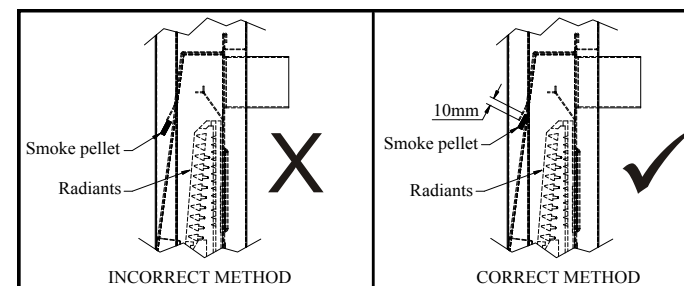

The installation is satisfactory if the smoke is drawn into the fire. If the smoke is not drawn into the fire relight the fire and leave on for a further 10 minutes and repeat the test. (This test should be carried out immediately after the fire has been turned off). If the smoke is still not drawn into the fire, the flue system may require attention. **IF THIS IS THE CASE, DISCONNECT THE FIRE AND SEEK EXPERT ADVICE.**

### INITIAL LIGHTING:

When the fire is first lit, it should be run on high setting for about 1 hour. Ensure the room is well ventilated and all doors and windows are open, this is to allow for any residual lubricants remaining from the manufacturing process to burn off.

### WORKING SURFACES:

Due to the nature of the appliance most surfaces on the appliance casing will become hot: in particular the warm air outlet, fireguard and appliance top. The customer should be advised on the need to avoid touching them wherever possible.

The areas around the control knob and ignition button are not classed as working surfaces and are perfectly safe to operate.